

Filter Housing SG ATEX Standard

The steel standard filter housings are designed for the purification of compressed air and gases in combustible environment. Due to the modular design of the housings different filter elements can be used.

Product description:

SG ATEX standard housings are designed for the purification of compressed air and gases in an industrial operation in combustible environment.

The flanged housings due to an optimized construction offer low differential pressures at high flow rates and as a standard equipped with an Econometer and a pneumatic drain.

A multitude of various housings with different connections, single or multiple, allow to match the requirements of the application, e. g. the compressor size. This product series offers 13 different housings ranging from a volume flow of 1080 m³/h to 38400 m³/h (related to 7 bar (ü) and 20°C).

The SG ATEX standard housings are suitable for the application in the zones 1 and 2 as well as 21 and 22.

For gases and vapours of the group IIC only devices **without** Econometer may be used.

The SG ATEX standard filter housing conforms to the requirements of the European directive 87/404/EG for simple pressure vessels and the ATEX directive.

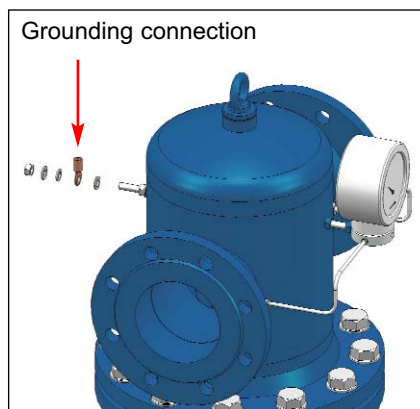

Technical Data

Materials:	
Filter housing, EG-type approval	Steel
Econometer: differential gauge	Plastic
Pneumatic drain	Aluminium
Sealing acc. to DIN 2690	Graphite with sheet metal insert made of stainless steel

Grounding connection:
To the avoidance of sparking due to static loading (explosion protection)

Maximum operating pressure:	
0108 - 0288	16 bar
0432 - 3840	16 bar

Maximum operating temperature:
+1°C / +65°C

Surface finish:
Polyester resin coating

Connection IN/OUT:
Flange DN 50 to DN 300; DIN 2633

Industrial filter SG ATEX 0108-0288

Pos.	Piece	Description
13	1	Grounding screw
12	1	Knurled nut
11	1	Anchor bolt
10	1	Lifting eye bolt
9	1	Washer
8	1	Hexagon nut
7	1	Hexagon bolt
6	1	Drain
5	1	Econometer
4	1	Filter element
3	1	Housing gasket
2	1	Lower housing bowl
1	1	Upper housing bowl

Max. operating-pressure:	16 bar
test pressure:	24 bar
Max. operating temperature:	+1°C / +65°C
Material:	carbon steel
Paint coat:	polyester resin coating

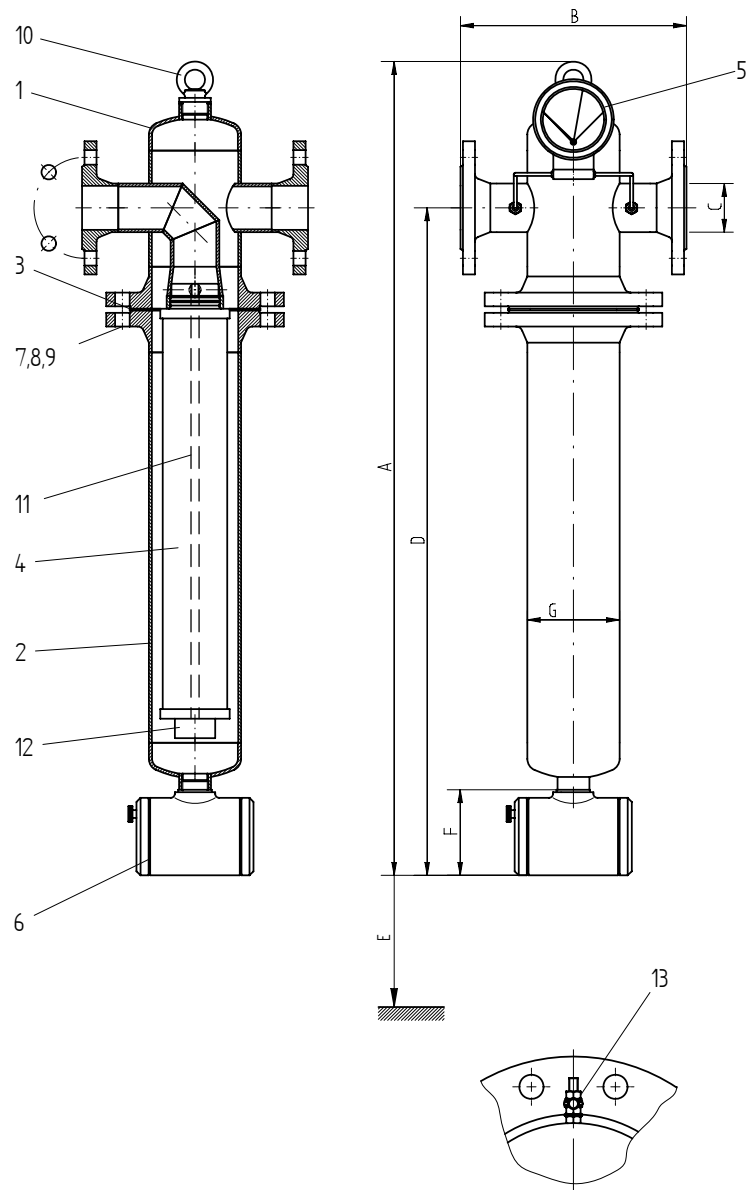

Size	Volume (l)	Weight* (kg)	A mm	B mm	C DIN 2633	D mm	E mm	F mm	ø G mm	Element
0108	7,5	28	1015	280	DN 50	830	450	105	114,3	15/30
0144	8,0	33	1015	280	DN 65	830	580	105	114,3	20/30
0192	16,0	40	1315	320	DN 80	1120	850	105	139,7	30/30
0288	23,5	54	1350	360	DN 80	1135	850	105	168,3	30/50

* without filter element

Industrial filter SG ATEX 0432-3840

Pos.	Description
13	Grounding screw
12	Knurled nut
11	Anchor bolt
10	Lifting eye bolt
9	Washer
8	Hexagon nut
7	Hexagon bolt
6	Drain
5	Economizer
4	Filter element
3	Housing gasket
2	Lower housing bowl
1	Upper housing bowl

Max. operating pressure:	16 bar
test pressure:	24 bar
Max. operating temperature:	+1°C / +65°C
Material:	carbon steel
Paint coat:	polyester resin coating

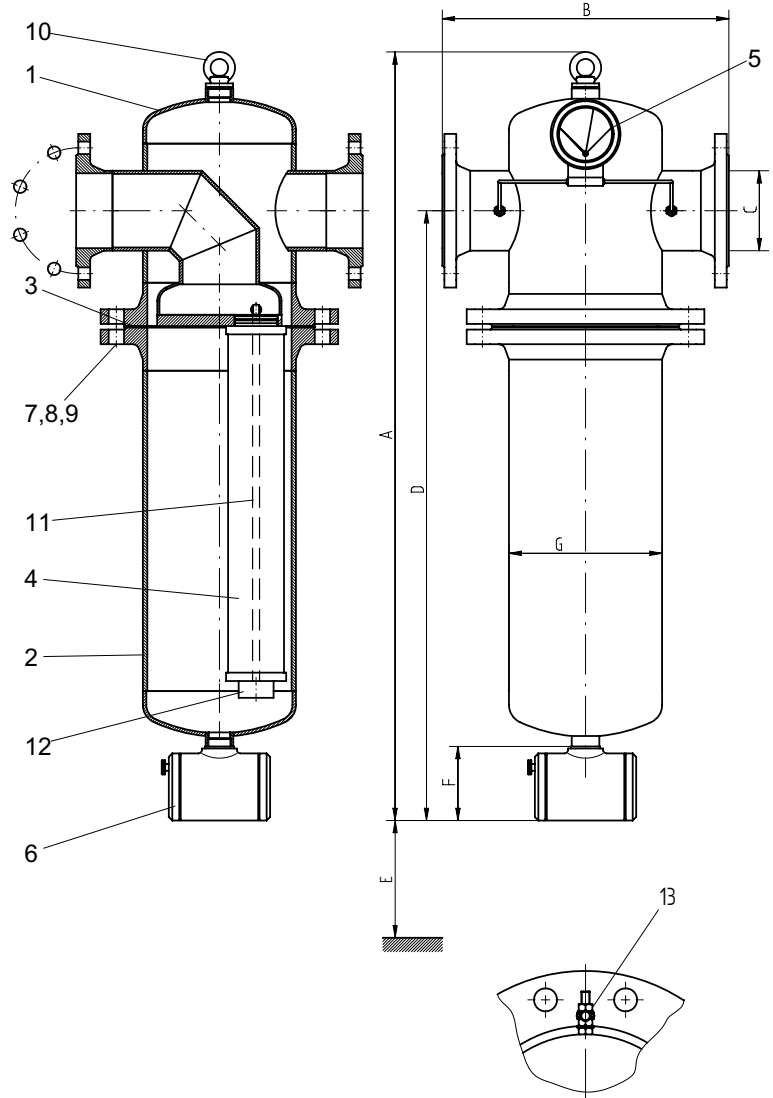

Size	Volume (l)	Weight* (kg)	A mm	B mm	C DIN 2633	D mm	E mm	F mm	ø G mm	Element
0432	31	80	1100	410	DN 100	870	580	105	219.1	3x20/30
0576	40	90	1370	410	DN 100	1140	850	105	219.1	3x30/30
0768	70	130	1485	480	DN 150	1210	875	105	273	4x30/30
1152	103	150	1510	540	DN 150	1225	875	105	323.9	6x30/30
1536	168	236	1625	660	DN 200	1285	875	105	406.4	8x30/30
1920	168	240	1625	660	DN 200	1285	875	105	406.4	10x30/30
2304	312	376	1730	800	DN 250	1350	875	105	508	12x30/30
3072	312	380	1730	800	DN 250	1350	875	105	508	16x30/30
3840	463	530	1870	930	DN 300	1445	900	105	600	20x30/30

* without filter element

Industrial filter SG ATEX 0108-0288 A

Pos.	Description
13	Grounding screw
12	Knurled nut
11	Anchor bolt
10	Lifting eye bolt
9	Washer
8	Hexagon nut
7	Hexagon bolt
6	Screw plug
5	Screw plug
4	Filter element
3	Housing gasket
2	Lower housing bowl
1	Upper housing bowl

Max. operating pressure:	16 bar
test pressure:	24 bar
Max. operating temperature:	+1°C / +65°C
Material:	carbon steel
Paint coat:	polyester resin coating

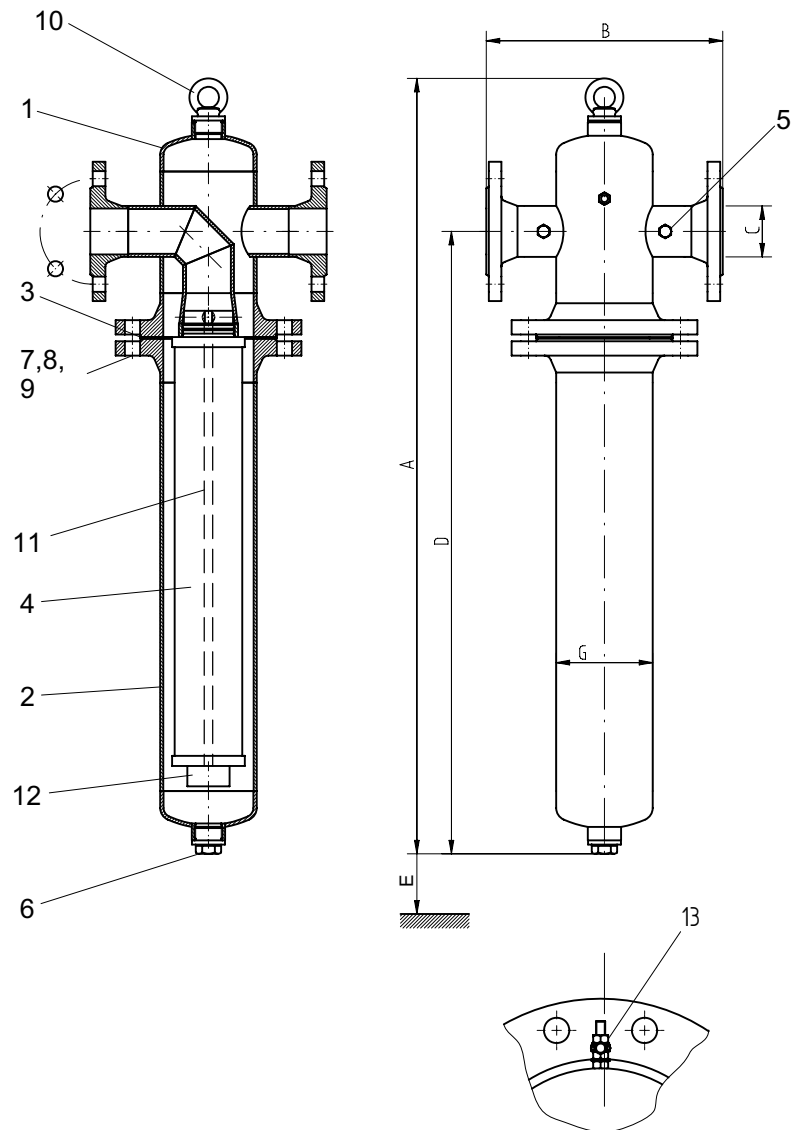

Size	Volume (l)	Weight* (kg)	A mm	B mm	C DIN 2633	D mm	E mm	ø G mm	Element
0108	7.5	25.5	930	280	DN 50	735	450	114.3	15/30
0144	8.0	30.5	930	280	DN 65	735	580	114.3	20/30
0192	16.0	37.5	1230	320	DN 80	1035	850	139.7	30/30
0288	23.5	51.5	1260	360	DN 80	1050	850	168.3	30/50

* without filter element

Industrial filter SG ATEX 0432-3840 A

Pos.	Description
13	Grounding screw
12	Knurled nut
11	Anchor bolt
10	Lifting eye bolt
9	Washer
8	Hexagon nut
7	Hexagon bolt
6	Screw plug
5	Screw plug
4	Filter element
3	Housing gasket
2	Lower housing bowl
1	Upper housing bowl

Max. operating pressure:	16 bar
test pressure:	24 bar
Max. operating temperature:	+1°C / +65°C
Material:	carbon steel
Paint coat:	polyester resin coating

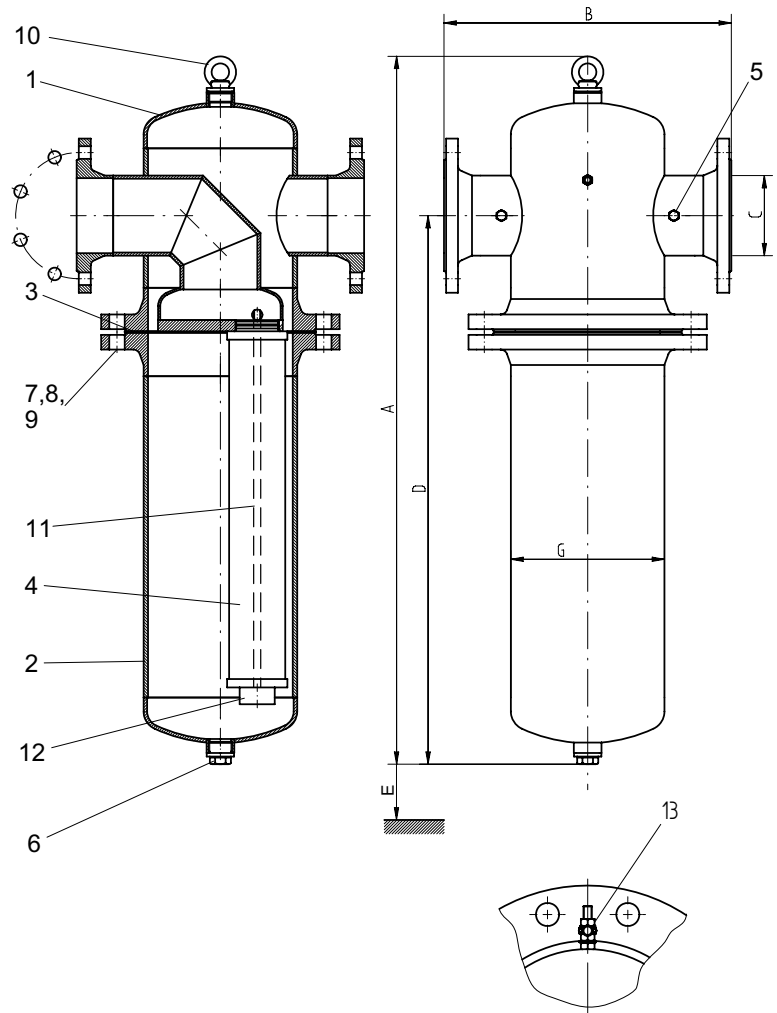

Size	Volume (l)	Weight* (kg)	A mm	B mm	C DIN 2633	D mm	E mm	ø G mm	Element
0432	31	77,5	1010	410	DN 100	780	580	219,1	3x20/30
0576	40	87,5	1280	410	DN 100	1050	850	219,1	3x30/30
0768	70	127,5	1400	480	DN 150	1120	875	273	4x30/30
1152	103	147,5	1425	540	DN 150	1140	875	323,9	6x30/30
1536	168	233,5	1535	660	DN 200	1195	875	406,4	8x30/30
1920	168	237,5	1535	660	DN 200	1195	875	406,4	10x30/30
2304	312	273,5	1650	800	DN 250	1270	875	508	12x30/30
3072	312	377,5	1650	800	DN 250	1270	875	508	16x30/30
3840	463	527,5	1780	930	DN 300	1355	900	600	20x30/30

* without filter element

Industrial filter SG ATEX 0108-0288 S

Pos.	Piece	Description
13	1	Grounding screw
12	1	Knurled nut
11	1	Anchor bolt
10	1	Lifting eye bolt
9	1	Washer
8	1	Hexagon nut
7	1	Hexagon bolt
6	1	Screw plug
5	1	Econometer
4	1	Filter element
3	1	Housing gasket
2	1	Lower housing bowl
1	1	Upper housing bowl

Max. operating pressure:	16 bar
test pressure:	24 bar
Max. operating temperature:	+1°C / +65°C
Material:	carbon steel
Paint coat:	polyester resin coating

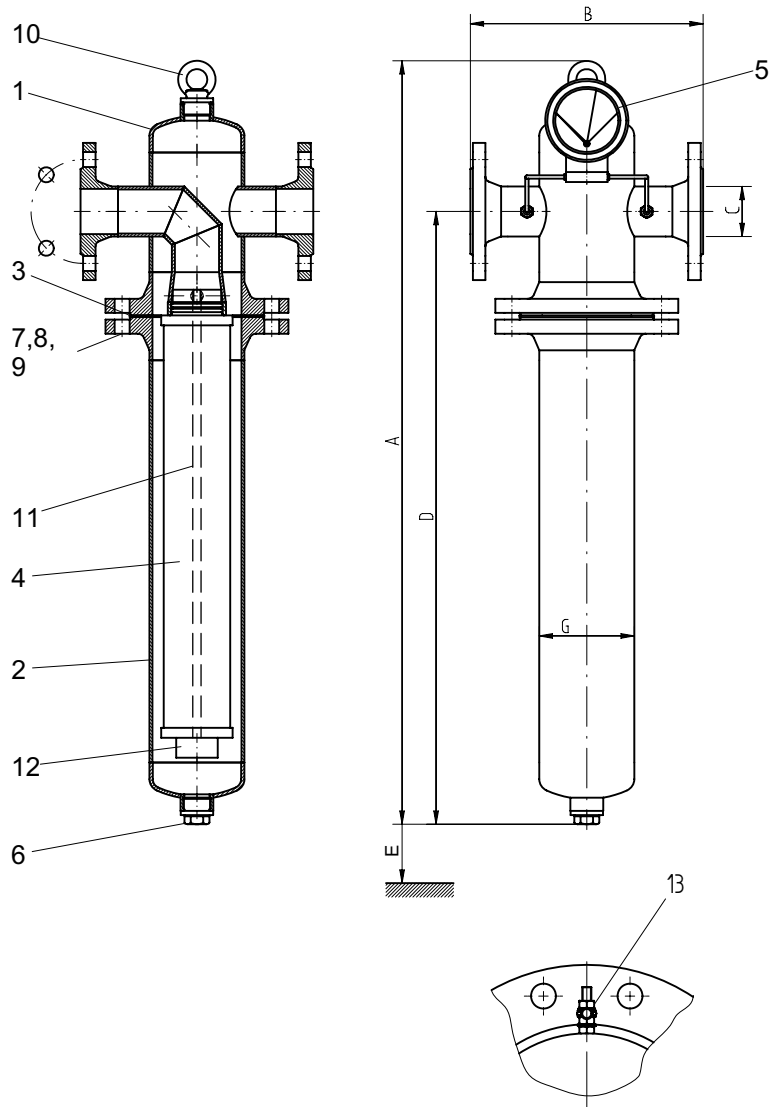

Size	Volume (l)	Weight* (kg)	A mm	B mm	C DIN 2633	D mm	E mm	ø G mm	Element
0108	7.5	26.5	930	280	DN 50	735	450	114.3	15/30
0144	8.0	31.5	930	280	DN 65	735	580	114.3	20/30
0192	16.0	38.5	1230	320	DN 80	1035	850	139.7	30/30
0288	23.5	52.5	1260	360	DN 80	1050	850	168.3	30/50

* without filter element

Industrial filter SG ATEX 0432-3840 S

Pos.	Description
13	Grounding screw
12	Knurled nut
11	Anchor bolt
10	Lifting eye bolt
9	Washer
8	Hexagon nut
7	Hexagon bolt
6	Screw plug
5	Econometer
4	Filter element
3	Housing gasket
2	Lower housing bowl
1	Upper housing bowl

Max. operating pressure:	16 bar
test pressure:	24 bar
Max. operating temperature:	+1°C / +65°C
Material:	carbon steel
Paint coat:	polyester resin coating

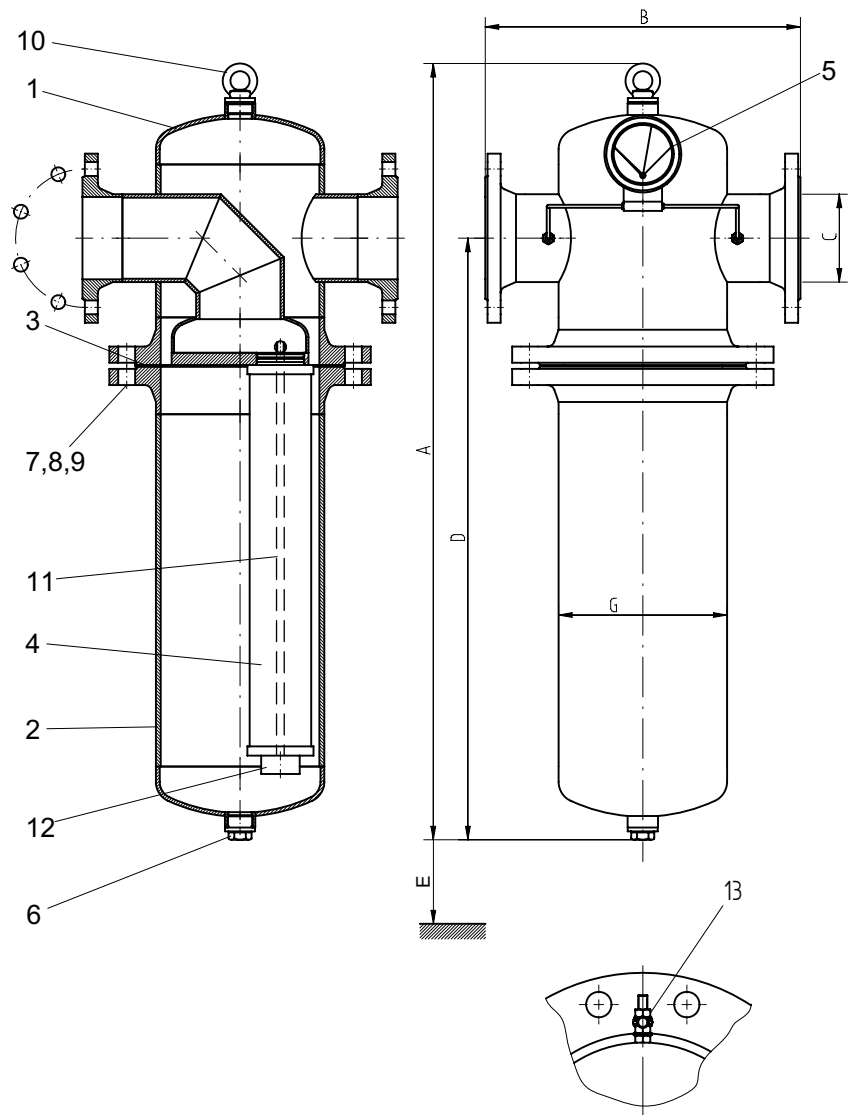

Size	Volume (l)	Weight* (kg)	A mm	B mm	C DIN 2633	D mm	E mm	ø G mm	Element
0432	31	78.5	1010	410	DN 100	780	580	219.1	3x20/30
0576	40	88.5	1280	410	DN 100	1050	850	219.1	3x30/30
0768	70	128.5	1400	480	DN 150	1120	875	273	4x30/30
1152	103	148.5	1425	540	DN 150	1140	875	323.9	6x30/30
1536	168	234.5	1535	660	DN 200	1195	875	406.4	8x30/30
1920	168	238.5	1535	660	DN 200	1195	875	406.4	10x30/30
2304	312	374.5	1650	800	DN 250	1270	875	508	12x30/30
3072	312	378.5	1650	800	DN 250	1270	875	508	16x30/30
3840	463	528.5	1780	930	DN 300	1355	900	600	20x30/30

* without filter element