

Ultrapac® HED/ALD/MSD Type 0005 to 1000

Complete purification package with heatless adsorption dryer, pre-, afterfilter and level-controlled electronic condensate drain.

Compressed air is lead through the inlet of the dryer (J) and across the prefilter (3). At this stage, the air is cleaned from particles and condensate. The condensate is removed via the level-controlled electronic condensate drain (11).

Via the lower shuttle valve (9), the air is lead into the adsorption vessel (1), in which the air is dried down to the required dewpoint. Via the upper shuttle valve (9), the air is let into an afterfilter (4), in which possibly released particles from the desiccant bed are retained. Via the outlet (O), the clean and dry air is lead into the compressed air network and to the point of use.

While one vessel is in the drying phase (adsorption), the other vessel is being dried again (regeneration).

A partial stream of dried air is expanded to atmospheric pressure via a nozzle (6) and lead across the desiccant bed for regeneration and via a solenoid valve (5) and a silencer (7) to the atmosphere.

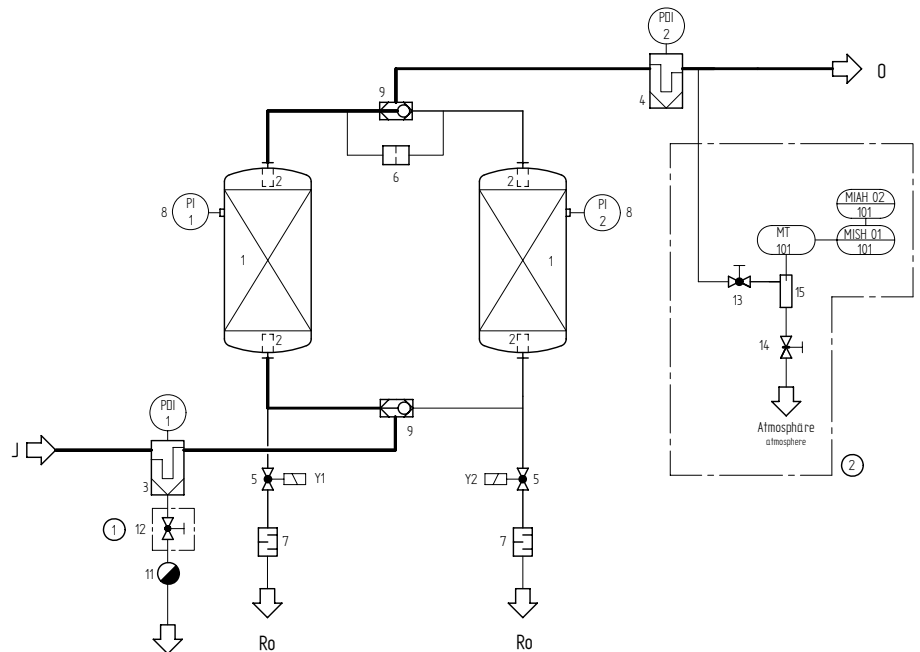

HED/ALD/MSD	Volume flow in m ³ /h (1 bar, 20°C)*	Regeneration air losses (average) m ³ /h (1 bar, 20°C)			Volume flow out (min.) m ³ /h (1 bar, 20°C)			Pressure loss initial mbar	Prefilter (Afterfilter) M (V)
		HED	ALD	MSD	HED	ALD	MSD		
0005	5	0.7	0.8	1	4.1	4.0	3.8	50	0035
0010	10	1.4	1.5	2	8.3	8.2	7.5	50	0035
0015	15	2.1	2.3	3	12.4	12.2	11.3	80	0035
0025	25	3.5	3.8	5	20.7	20.3	18.9	80	0070
0035	35	4.9	5.3	7	29.0	28.5	26.4	90	0070
0050	50	7.0	7.5	10	41.4	40.8	37.7	85	0210
0080	80	11.2	12.0	16	66.2	65.2	60.3	100	0210
0100	100	14.0	15.0	20	82.8	81.6	75.4	105	0210
0150	150	21.0	23.0	30	124.2	121.7	113.1	155	0210
0175	175	24.5	26.3	35	144.9	142.7	132.0	90	0210
0225	225	31.5	34.0	45	186.3	183.2	170.0	105	0450
0300	300	42.0	45.0	60	248.3	244.7	226.2	140	0450
0375	375	52.5	56.0	75	310.4	306.1	282.8	165	0450
0550	550	77.0	83.0	110	455.3	447.9	414.7	165	0600
0650	650	91.0	98.0	130	538.1	529.5	490.1	200	0750
0850	850	119.0	128.0	170	703.6	692.6	640.9	235	1100
1000	1000	140.0	150.0	200	827.8	815.5	754.0	200	1100

* related to 1 bar (abs) and 20 °C at intake of compressor and 7 bar (g) and 35 °C inlet temperature



HED/ALD/MSD 0005-1000

Features HED/ ALD/ MSD:	Benefits
Purification package complete with pre-,afterfilter and condensate drain	Turnkey system, no additional installation required, all components from one hand, technically perfectly matched to each other
Prefilter with electronic, level-controlled drain UFM-T	No compressor air losses due to condensate removal, therefore reduction of operating costs
All dryers in cabinet construction	Optimum protection against mechanical damage and against dirt
Generous dimensioned filters	Large filtration surface, therefore low pressure drop and low operating costs
Display of operating status by LED	High operating safety, since all operating status can be detected easily at any time
Intermittent operation standard	Link between dryer and compressor possible on central applications, therefore saving of compressed air
17 sizes available, matched to the compressor flows, with 3 pressure dewpoints each, for choice	Custom made solutions possible, matching exactly customer's requirements; no oversizing of compressors necessary, since lowest possible regeneration air requirements
Comprehensive option package: Dewpoint depending control, start-up device, bypass, pneumatics control, change-over control etc.	Flexibility in application, well thought-o package for economical operation and safe system installation in the compressed air network

Product description:
HED/ALD/MSD: Complete purification package with heatless adsorption dryer, which works on the basis of pressure swing adsorption, with integrated pre- and afterfilter and electronic, level controlled condensate drain

Medium:
Compressed air/ nitrogen

Pressure dewpoint:
HED: -20 °C, ALD: -40 °C, MSD: -70 °C at 100% load

Operating pressure:
min. 4 bar (g) max. 16 bar (g)

Medium temperature:
max. +50 °C

Ambient temperature:
min. +4 °C, max. +50 °C

Power supply:
230 V/ 115 V AC/ 50 – 60 Hz, 24 V DC

Power consumption:
approx. 40 W

Pressure vessel – design, manufacture, testing:
Absorber: acc. to 87/404/EEC Filter: acc. to 97/23/EC

Declaration of conformity:
Type 0005 – 0175: acc. to 2006/95/EC
Type 0225 – 1000: acc. to 97/23/EC

Sizing:

Operating pressure bar (g)	4	5	6	7	8	9	10	11	12	13	14	15	16
Correction factor overpressure (f _p)	0.63	0.75	0.88	1.0	1.12	1.25	1.38	1.50	1.63	1.75	1.88	2.0	2.13

Type	Pressure-Dewpoint	Residual water content	Inlet temperature °C	20	25	30	35	40	45	50
HED	-20°C	0.88 g/m ³	Correction factor HED Temperature (f _T)	-1.2	1.2	1.1	1.0	-	-	-
			Pressure dewpoint (°C)	-20	-20	-20	-20	-	-	-
ALD	-40°C	0.11 g/m ³	Correction factor ALD Temperature (f _T)	-1.2	1.2	1.1	1.0	-	-	-
			Pressure dewpoint (°C)	-40	-40	-40	-40	-	-	-
MSD	-70°C	0.0027 g/m ³	Correction factor MSD Temperature (f _T)	-1.0	-1.0	1.0	1.0	0.8	0.7	0.5
			Pressure dewpoint (°C)	-70	-70	-70	-70	-65	-55	-50

Example:
 $\dot{V}_{nom} = 200 \text{ m}^3/\text{h}$, inlet temperature = 30°C, operating pressure = 10 bar (g), PDP -40°C

$$\dot{V}_{corr} = \frac{\dot{V}_{nom}}{f_p \cdot f_T} = \frac{200 \text{ m}^3/\text{h}}{1.38 \cdot 1.1} = 131.8 \text{ m}^3/\text{h}. \text{ Calculated dryer size: Ultracac ALD, type 0150}$$

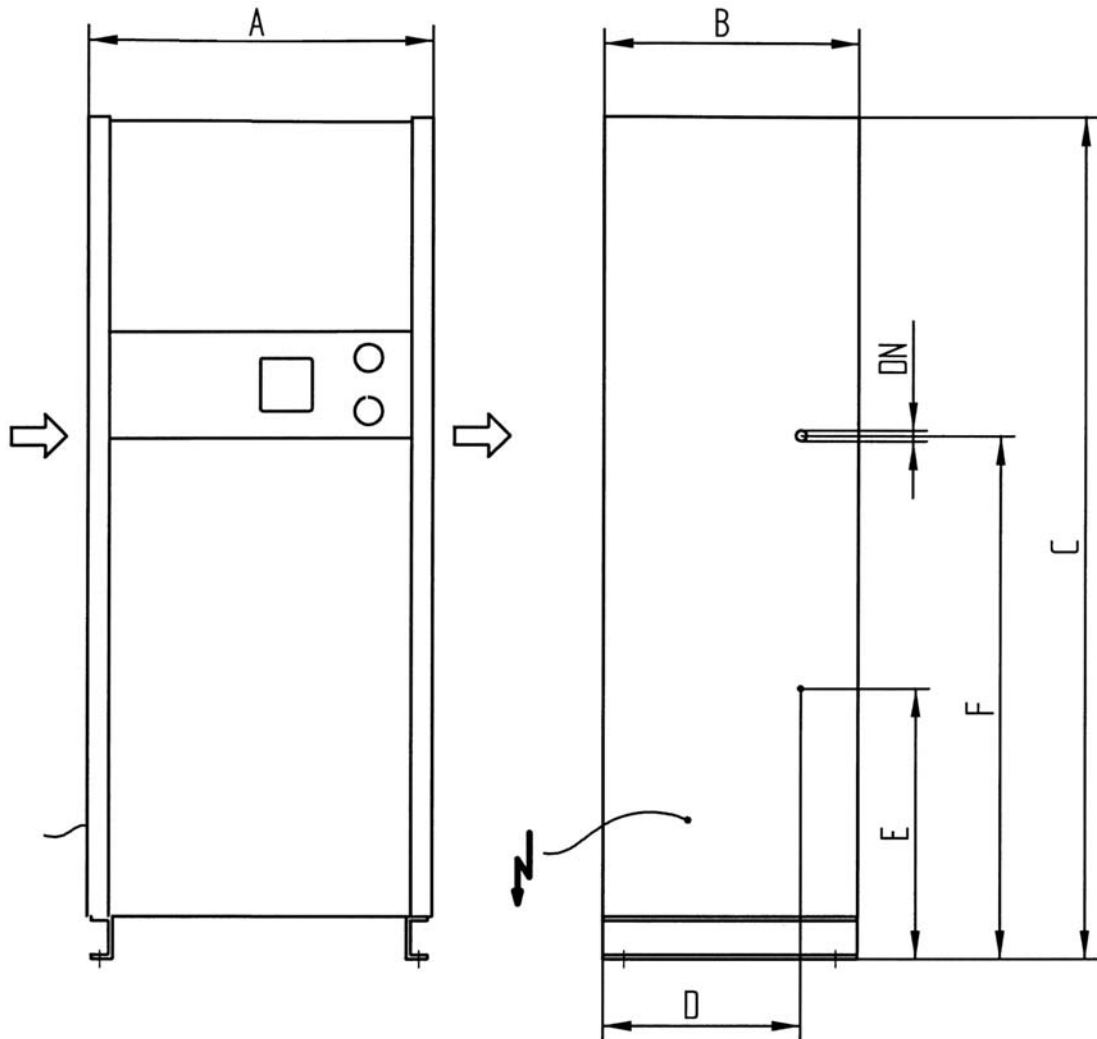
HED/ALD/MSD 0005-1000

HED/ALD/MSD	DN "	A mm	B mm	C mm	D mm	E mm	F mm	Weight kg
0005	G 3/8	470	340	700	255	145	390	27
0010	G 3/8	470	340	700	255	145	390	33
0015	G 3/8	470	340	1060	255	310	700	41
0025	G 1/2	470	340	1060	255	310	700	44
0035	G 1/2	470	340	1060	255	310	700	48
0050	G 3/4	670	460	1610	315	415	800	107
0080	G 3/4	670	460	1610	315	415	800	140
0100	G 1	670	460	1610	315	415	800	169
0150	G 1	770	680	1980	465	535	1075	200
0175	G 1	770	680	1980	465	535	1075	260
0225	G 1 1/2	770	680	1980	465	535	1075	277
0300	G 1 1/2	770	680	1980	465	535	1075	321
0375	G 1 1/2	950	770	2190	530	660	1250	398
0550	G 2	950	770	2190	530	660	1250	431
0650	G 2	950	770	2190	530	660	1250	506
0850	G 2	1100	880	2350	650	650	1450	595
1000	G 2	1100	880	2350	650	650	1450	676